

Getting more power from an engine is something all racers are familiar with. Getting that power to the ground, however, is a science that few racers really understand. For those of you just starting out in drag racing, we've put together a basic overview of how chassis and suspension systems are affected by sudden acceleration. The Chassis People™ at Competition Engineering want you to understand the relationship between engine power and the chassis, suspension and driveline systems of your car. By doing so, you will be in a better position to select equipment that allows you to hook up and lower ET's!

Without the right chassis and suspension setup, all the horsepower in the world will only go up in tire smoke!

As you're trying to understand how modifications to the chassis and suspension systems improve traction, it helps to keep one thing in mind. Power produced by your engine must take a direct path to "planting" the tires and "launching" your car forward. Any power that gets absorbed by the chassis and suspension is power that can't be used to get you to the finish line as quickly as possible.

There's a basic law of physics that states "for every action there is an equal and opposite reaction." Relating this principle to a game of billiards is relatively easy. But applying it to chassis and suspension systems on a drag

race car is more complex. When trying to understand how chassis and suspension setups affect traction, keep the "action/reaction" concept in mind. It will make things much easier to understand.

While race cars are designed for racing, street cars are designed primarily for carrying passengers safely and comfortably. From the factory, passenger cars are not equipped to handle high rpm launches from a standing start. This instant release of power places great strain on stock suspension systems and usually results in unwanted wheel hop, tire spin and parts breakage. Controlling this unwanted reaction is the job of a traction device, which limits the rotation of the rear axle housing and transfers forces to the track surface.

For example, the installation of traction bars is a popular way of limiting rotation of the rear axle housing. Traction bars mount directly to each side of the axle housing and extend forward like long arms or levers. When the housing begins to rotate during initial launch, the traction bars stop this action, holding the housing in place and converting some of the applied torque to a force which pushes the rear tires into the track surface. By stabilizing the axle housing, wheel hop is virtually eliminated, acceleration is smoother and parts breakage is minimized.

HOW "WHEEL HOP" OCCURS

REAR AXLE HOUSING ROTATION WITHOUT TRACTION CONTROL

When horsepower is suddenly delivered to the differential, whether from a clutch or a torque converter, the pinion attempts to "climb" the ring gear. This sudden shock of torque causes the entire rear axle housing to rotate backwards in a counter-clockwise direction. This causes the springs to distort, resulting in severe driveshaft/U-joint misalignment.

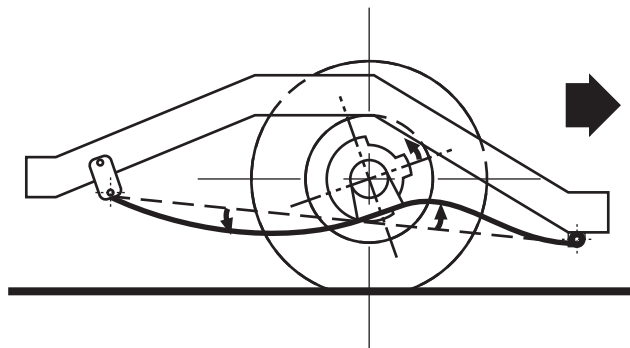

SPRING REACTION UNLOADS SUSPENSION, CAUSING "WHEEL-HOP"

The axle housing is allowed to continue its rotation until it meets resistance from the suspension/springs, which then try to "snap" the housing back to its original position. As power continues to the differential, the housing is once again allowed to rotate back against the springs. This action/reaction of the suspension, commonly known as "wheel hop," continues much like a tug-of-war. Instead of launching your car forward, you sit there bouncing around and spinning your wheels.

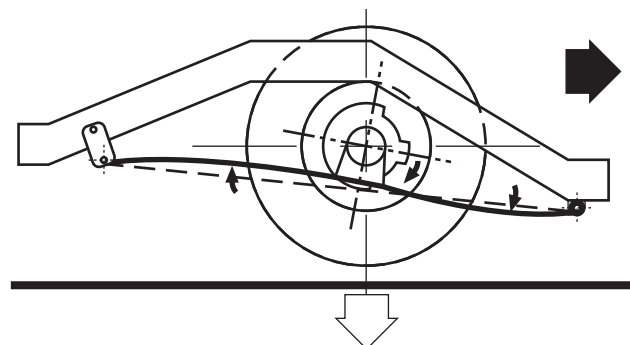



COMPETITION ENGINEERING

TRACTION BAR LIMITS AXLE ROTATION

The bolt-on “Slapper Bar” is one of the most basic traction devices available. Originally pioneered by Bill “Grumpy” Jenkins in the mid-sixties, it gets its name from the way it works. One end of the Traction Bar replaces the stock spring pad and is clamped to the rear axle housing. The front end of the bar is suspended just below the spring eye. When the housing begins to rotate during launch, the bar also rotates until it contacts or “slaps” the spring. (Unlike other brands, Competition Engineering Traction Bars make contact directly below the front spring eye, preventing spring damage). When contact occurs, the Slapper Bar becomes a lever trying to push the axle housing down and planting the tires in the process.

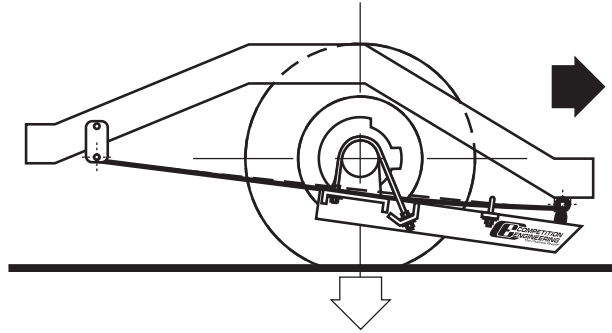

SLIDE-A-LINK™

A revolutionary, patented, completely bolt-on traction device, the Slide-A-Link™, designed for both street and strip use is track tested and competition proven to outperform conventional “Slapper” bars. A solid mounted front plate is installed inside the original front spring pocket and clamps to the leaf spring to provide a positive displacement for the torque that is transmitted from the rear axle through the telescoping bar and special durometer shock pad. These forces, along with improved instant center geometry, provide better weight transfer for increased traction. Free travel and pre-load adjustments are made on the vehicle by adjusting the jack screw at the rear of the bar.

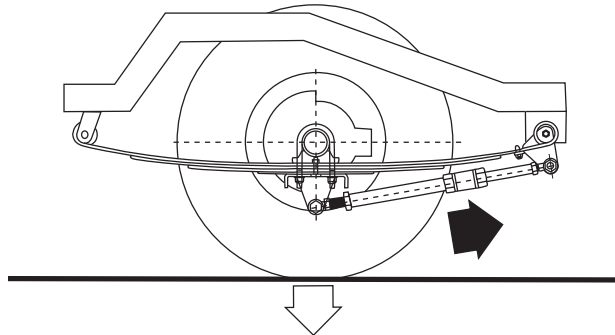

HOW LADDER BARS WORK

The Ladder Bar is a more sophisticated traction device because it serves as an extremely rigid, bridge-type truss that locates the rear axle housing directly to the chassis. With the axle housing held firmly in place, the torque applied to the differential is now transferred immediately through the Ladder Bars and into the chassis. By using the Ladder Bar to carry power to the chassis, the front end reacts by rising. As the front of the car travels upward, rapid weight transfer is created which “plants” the rear tires and propels the car forward.

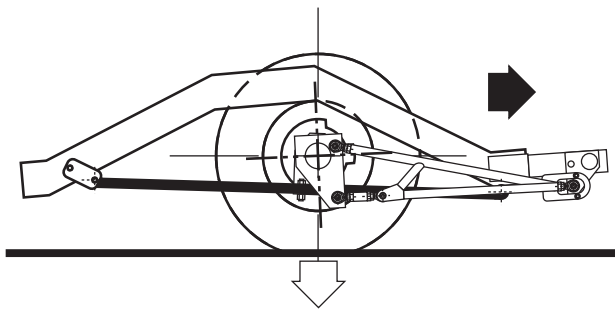

HOUSING FLOATERS ELIMINATE SUSPENSION BIND

When using Ladder Bars with a leaf spring rear suspension, the axle housing cannot be rigidly attached to the springs. If it were, severe binding of the rear suspension would occur because the Ladder Bar and the leaf spring both travel in separate competing arcs. By allowing the housing to rotate and glide on the leaf spring, the Floating Housing Mount eliminates the bind and allows the Ladder Bars to work the way they were designed.

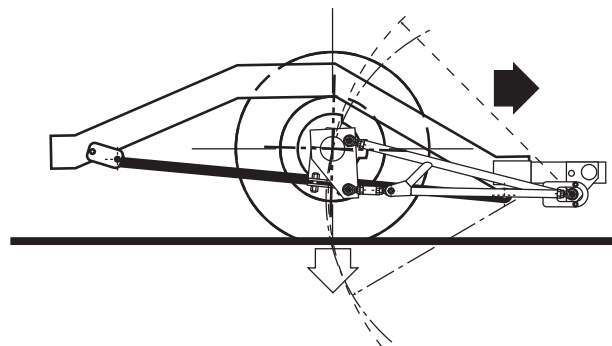

Traction devices are only half the story. When used properly to transfer the torque action created in the differential into the chassis, other aspects of the car must also be enhanced. Since the chassis is the backbone of the car, the “action” of transferring power into it must not result in the “reaction” of twisting and flexing. Therefore, the chassis must be as rigid as possible. Frame Connectors are used to connect front and rear uni-body subframes, effectively making them one piece. This eliminates unwanted flex in the chassis and prevents it from absorbing the power needed for acceleration. Solid Body Mounts, Solid Motor Mounts, Engine Torque Links and Solid Transmission Mounts contribute to forming a rigid structure and help eliminate unwanted twisting and power loss.

Large-diameter Tubular Control Arms, which are much stronger than stock units, also add rigidity, eliminate flex and help direct power to the ground. Finally, Roll Bars and Roll Cages help make the chassis and body solid while providing an extra measure of safety.

The suspension also contributes to overall performance. It serves as a flexible connection to the track, providing mechanical and hydraulic damping to control unwanted body and chassis movements. The suspension must remain flexible enough to offer a sufficient level of comfort and safety, while contributing to traction when subjected to

sudden acceleration. Installation of Competition Engineering's Adjustable Drag Shocks are one of the first steps taken to help stabilize suspension movement. In race applications, the front shocks play a dual role. When the front end lifts, they extend freely to increase weight transfer. When the front end begins to lower, these same shocks provide resistance to maximize the duration of weight transfer. Complementing the action of the shocks are Front Drag Springs, specially engineered for each application to hold a great amount of stored energy for instantaneous weight transfer. Rear Coil Springs are also available for specific vehicle weights to obtain the correct ride height, and provide full suspension travel for optimum weight transfer and traction. Stabilizer Bars are used in conjunction with both Ladder Bars and 4-Links. They center the rear axle housing within the chassis. This prevents lateral movement between the body and the suspension, which helps to provide high speed stability.

We hope that our introduction to chassis, suspension and traction systems has been helpful. From our simplified explanations you should realize that horsepower, while important, is not the only factor contributing to elapsed time results. A properly tuned chassis and suspension will convert engine power into traction. Our next section will help you to determine the level of equipment needed to obtain that traction.

WHEEL-E-BARS™ HELP CONTROL WEIGHT TRANSFER

Although Ladder Bars and 4-Links provide lift to the front end by transferring weight to the rear, too much lift detracts from the forward motion and reduces overall performance. Installation of Wheel-E-Bars™ helps to maintain the correct amount of lift and controls weight transfer to maximize traction.

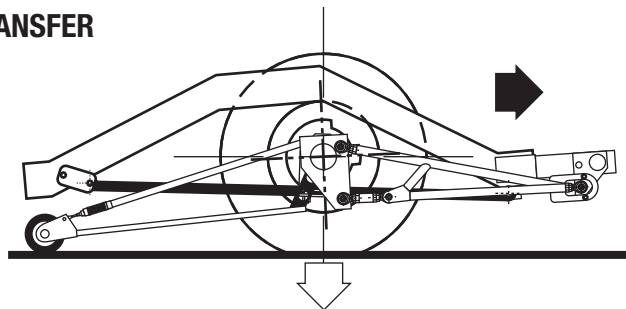

LADDER BARS VS. 4-LINKS

4-Links offer more adjustment over Ladder Bars and can handle higher torque loads. With two bars per side, one on top and one on the bottom, you basically have an open ended Ladder Bar. You can adjust the suspension for different track conditions by manipulating the mounting positions in the frame and axle housing brackets. This gives you the option of making the intersection point, or point of “instant center,” as far forward or rearward to suit your particular needs. The point of instant center is the location where the upper and lower links would intersect if imaginary lines extended from the front of the 4-Link bars. Unlike a Ladder Bar where the point of instant center is always located at the bar's front mounting point, the instant center on a 4-Link changes quickly as the car is launched.

